

**Vixen<sup>®</sup>**

# VMC260L for SXD

VIXEN ORIGINAL MAKUSUTOV CASSEGRAIN

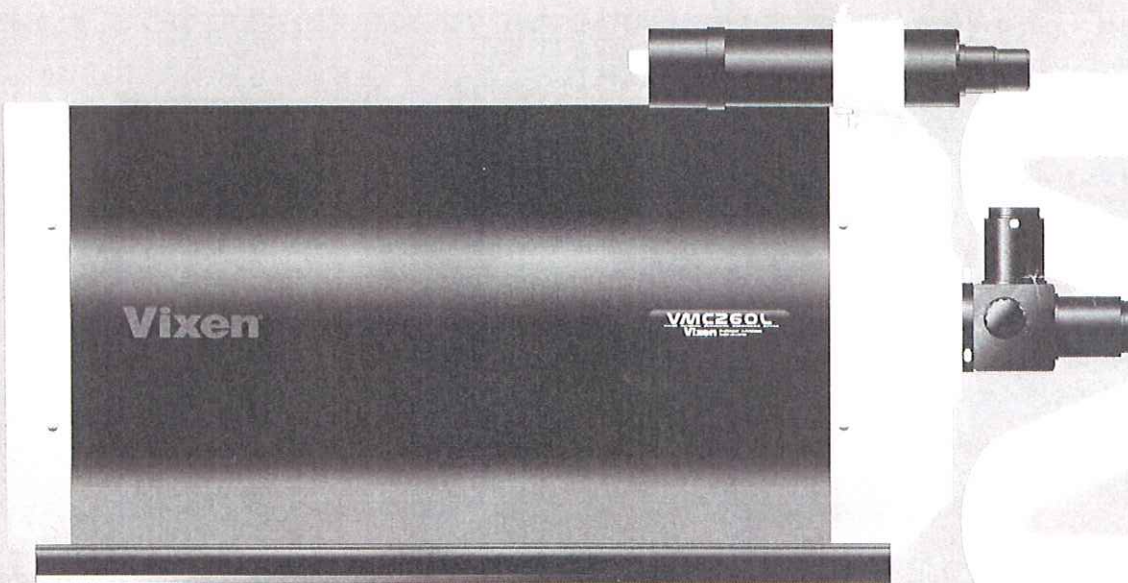

## PREFACE

Thank you very much for your purchase of a Vixen astronomical telescope.

This manual applies to the VMC260L telescope for the SXD equatorial mount. You may occasionally find descriptions in the text not relevant to your particular model. Read the instructions for your mount along with this manual if you purchased the telescope as a complete package.

## WARNING

**Never look directly at the sun with the telescope or its finder scope or guide scope. Permanent and irreversible eye damage may result.**

### ⊘ CAUTION

- ⊘ Do not leave the optical tube uncapped in the daytime. Sunlight passing through the telescope or finder scope may cause a fire.
- ⊘ Do not use the product while moving or walking, injuries could result from a collision with objects or from stumbling or falling.
- ⊘ Keep small caps, plastic bags, or plastic packing materials away from children. These may cause a danger of swallowing or suffocation.
- ⊘ Do not use the product in a wet environment and do not handle with wet hands.

## SETTING UP

Refer to your mount instructions along with this manual.

### ● Attaching the Finder Scope

① With the Allen wrench, loosen each of the rear three setscrews on the bracket ring that holds the finder scope. Loosen the front adjustment screws on the bracket ring to allow passage of the finder scope.

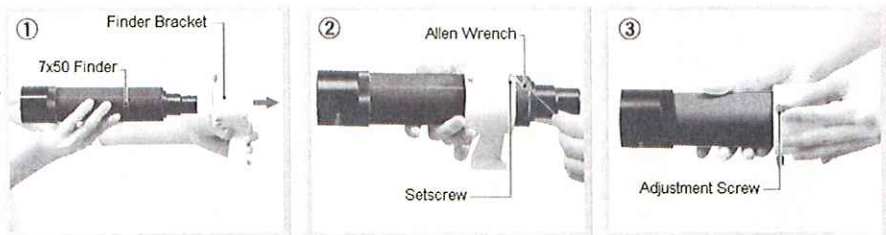

② Slide the finder scope into the bracket ring from its eyepiece end and tighten the setscrews on the bracket ring lightly with the Allen wrench.

③ Tighten the three adjustment screws to hold the finder scope steady.

④ Loosen the chrome setscrew of the bracket shoe on the telescope. Slide the finder scope onto the bracket shoe and tighten the chrome setscrew.

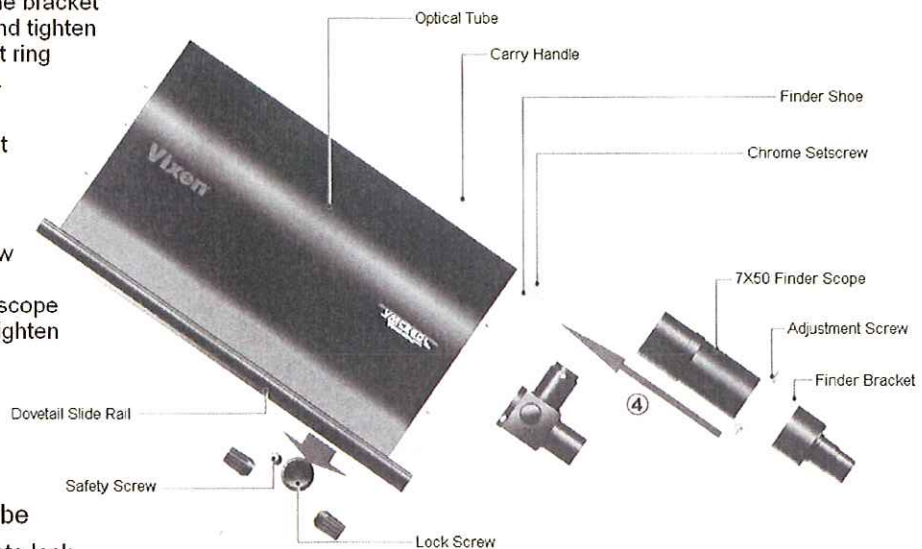

### ● Attaching the Optical Tube

① Loosen the dovetail tube plate lock screw and the safety screw before you attach the optical tube.

② Slide the dovetail slide rail on the bottom of the optical tube onto the mounting platform. Tighten the lock screw on the slide rail until snug. Tighten the safety screw.



## ALIGNING THE FINDER SCOPE

### ● Adjusting the Finder Scope

- 1 Choose a conspicuous target in the distance and place the target in the center of the field of view of the telescope.

In the illustration, a distant tower is brought into the center of the field of view of the telescope.

- 2 As you look through the finder scope, you should find the same target somewhere within the finder's field of view. The finder scope has a crosshairs.

- 3 Align the optical axis (field of view) of the finder scope with the optical axis (field of view) of the telescope. Adjust the finder scope by loosening or tightening two of the three adjustment screws at a time, in turn, until the target is in the same position, in the center of the crosshairs.

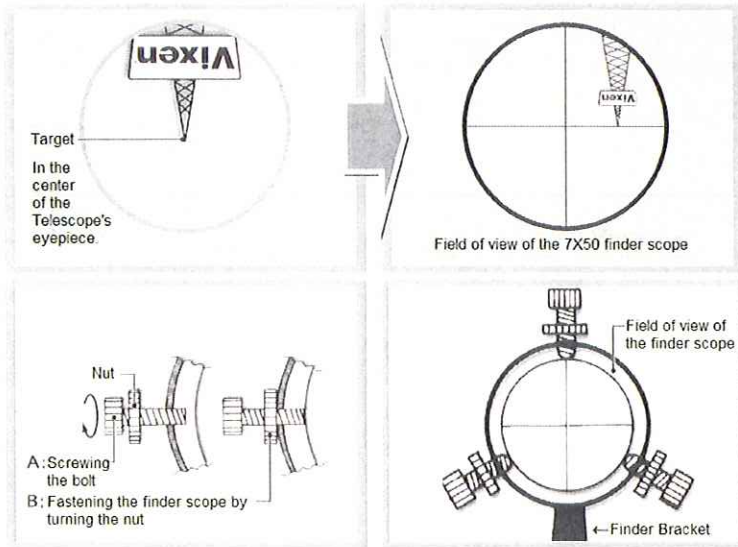

The telescope requires eyepieces to view images. An eyepiece is not included with the VMC260L.

## ACCESSORY CHART

### 【Visual Configuration】

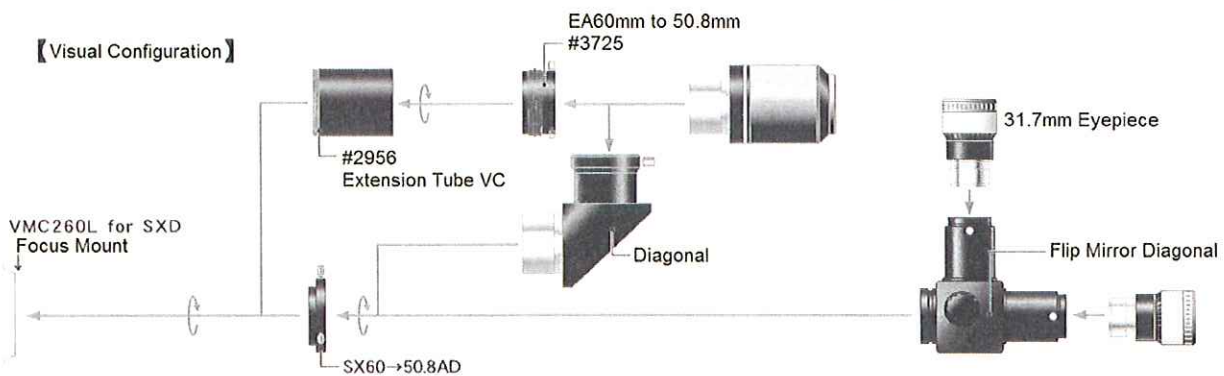

### 【Photographic Configuration】

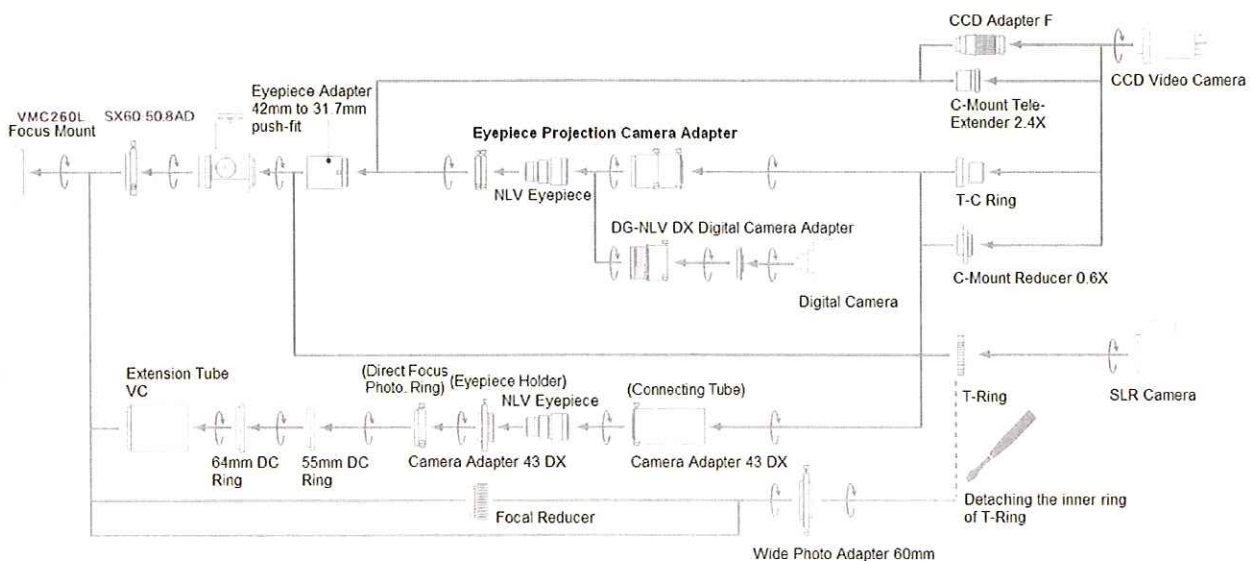

# RE-COLLIMATION

## How to Re-collimate the VMC260L Optical Tube

The VMC260L telescopes are collimated properly at Vixen's factory before shipment. The telescopes hold the collimation unless they are handled roughly. You can re-collimate your telescope using the following procedure if necessary.

- ① There are three Allen screws for collimation which are placed near the center the four-vane spider on the front of the optical tube.

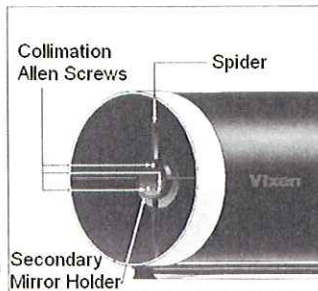

- ② Attach an eyepiece with medium power (60X to 80X) onto the eyepiece holder and get a relatively bright star such as the Polar star into the telescope's field of view. Turn the focus knob to defocus the star image fully until it is enlarged and blurred as much as one third of the viewing field. The silhouette of the secondary mirror is seen near the center of the blurred star image at this time.

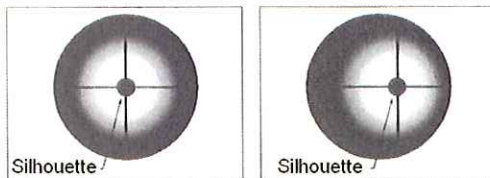

- ③ If the optical axis is aligned correctly, both the blurred star image and silhouette of the secondary mirror can be seen at the center of the telescope's field of view. If it is not aligned concentrically, move those images to the center of the field of view. With an Allen wrench, adjust the collimation screw nearest or furthest from the direction of those images.

- ① Re-collimation of the optical axis will go much faster if you have an assistant.  
 ② The star image will shift considerably even if the collimation screws are adjusted only a small amount.  
 ③ If one of the three collimation screws comes to the end in either direction, turn the other two collimation screws on the opposite side to the reverses so that you can continue the re-collimation.  
 ④ Optical collimation is very delicate and you should avoid turning the collimation screws excessively.

- ④ Turn the collimation screw clockwise or counterclockwise gradually until the blurred star image and silhouette of the secondary mirror are aligned concentrically in the center of the telescope's field of view.

- ⑤ Use an eyepiece with high magnification and repeat the above procedures so that you can make more precise re-collimation of the optical axis.

- ⑥ When re-collimation of the telescope is done properly, you perform a star test with a medium to high power eyepiece selecting a star of the second or third magnitude.



Right after you focus on the star precisely, defocus the star image slightly to look at a diffraction pattern of the star.

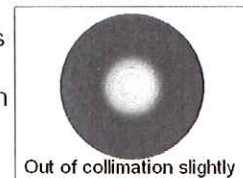

If the concentric diffraction rings can be seen, the optical axis have been re-collimated properly.

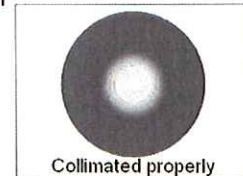

## Specifications

Model	VMC260L Optical Tube Assembly
Optical Design	Precision Spherical Mirror & Meniscus Lens System
Effective Aperture	260mm
Focal Length	3000mm
Focal Ratio	1 : 11.5
Light Gathering Power	1380X
Resolving Power	0.45 arc seconds
Limiting Magnitude	13.8
Threads	60mm, 42mm for T-ring
Visual Back	50.8mm (2.0"), 31.7mm (1.25")
Optical Tube Length	650mm
Outer Diameter	304mm
Weight	10.9 Kgs (24 lbs)
7X50 Finder Scope (6.8 degrees field of view)	Supplied
Flip Mirror Diagonal	Supplied
Mounting System	Dovetail Side Rail and Mounting Platform
Carry Handle	Supplied

## Handling and Storage

- Do not leave the product inside a car in bright sunshine or in other hot places. Keep away strong heat sources away from the product.
- When cleaning, do not use solvents such as paint thinner or similar products.
- Avoid touching any lens or mirror surfaces directly with your hands. In case a lens or mirror becomes dirty with fingerprints or general smears, gently wipe it using a commercially available lens cleaner and a lens cleaning paper or cloth, or consult your local Vixen dealer.
- Blow off dust on lenses using a commercially available blower brush.
- For storage, keep the product in a dry place and do not expose to direct sunlight.